

Write your name here

Surname

Other names

Pearson Edexcel
International
Advanced Level

Centre Number

--	--	--	--	--	--

Candidate Number

--	--	--	--	--	--

Physics

Advanced

Unit 4: Physics on the Move

Monday 18 January 2016 – Morning
Time: 1 hour 35 minutes

Paper Reference

WPH04/01

You do not need any other materials.

Total Marks

Instructions

- Use **black** ink or ball-point pen.
- **Fill in the boxes** at the top of this page with your name, centre number and candidate number.
- Answer **all** questions.
- Answer the questions in the spaces provided
– *there may be more space than you need.*

Information

- The total mark for this paper is 80.
- The marks for **each** question are shown in brackets
– *use this as a guide as to how much time to spend on each question.*
- Questions labelled with an **asterisk** (*) are ones where the quality of your written communication will be assessed
– *you should take particular care with your spelling, punctuation and grammar, as well as the clarity of expression, on these questions.*
- The list of data, formulae and relationships is printed at the end of this booklet.
- Candidates may use a scientific calculator.

Advice

- Read each question carefully before you start to answer it.
- Keep an eye on the time.
- Try to answer every question.
- Check your answers if you have time at the end.

Turn over ►

P46954A

©2016 Pearson Education Ltd.

1/1/1/1/



PEARSON

SECTION A

Answer ALL questions.

For questions 1–10, in Section A, select one answer from A to D and put a cross \boxtimes .
If you change your mind, put a line through the box \boxtimes and then
mark your new answer with a cross \boxtimes .

- 1 The unit for capacitance is the farad.
The farad can also be written as

- A A s V^{-1}
 B $\text{A s}^{-1} \text{V}^{-1}$
 C $\text{A}^{-1} \text{s}^{-1} \text{V}$
 D $\text{A}^{-1} \text{s V}$

(Total for Question 1 = 1 mark)

- 2 Which graph shows how the electric field strength E due to a negative point charge varies with distance r from the charge?

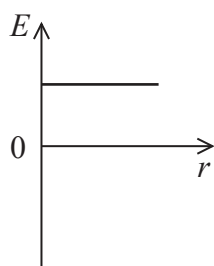

A

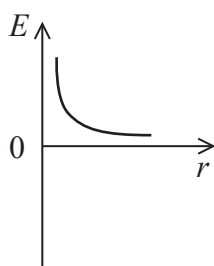

B

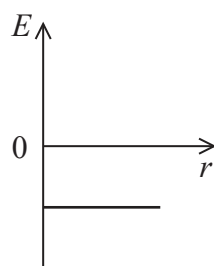

C

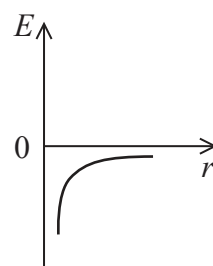

D

- A
 B
 C
 D

(Total for Question 2 = 1 mark)

DO NOT WRITE IN THIS AREA

DO NOT WRITE IN THIS AREA

DO NOT WRITE IN THIS AREA



- 3 The diagram shows a coin on a horizontal surface which is rotating at a constant angular velocity ω .

Which arrow correctly shows the direction of the frictional force on the coin?

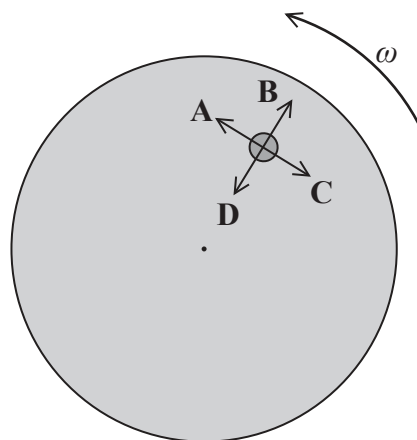

- A
- B
- C
- D

(Total for Question 3 = 1 mark)

- 4 Two charges $+Q$ and $-Q$ are located as shown on the diagram. \times is the point halfway between the two charges.

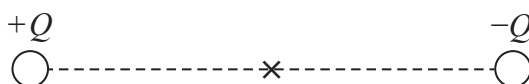

A small positive charge moves from $+Q$ to $-Q$.

Which statement about the resultant force on this charge, as it passes through \times , is correct?

- A The magnitude of the resultant force is a maximum.
- B The magnitude of the resultant force is a minimum.
- C The resultant force changes direction.
- D The resultant force is zero.

(Total for Question 4 = 1 mark)



- 5 Two parallel plates have a potential difference of 12 V across them and are separated by a distance of 5.0×10^{-4} m.

What is the magnitude of the electric field strength halfway between the plates?

- A 6000 V m^{-1}
 B $12\,000 \text{ V m}^{-1}$
 C $24\,000 \text{ V m}^{-1}$
 D $48\,000 \text{ V m}^{-1}$

(Total for Question 5 = 1 mark)

- 6 The Large Hadron Collider is designed to accelerate protons to very high energies for particle physics experiments. Very high energies are required to

- A annihilate hadrons.
 B collide hadrons.
 C create particles with large mass.
 D produce individual quarks.

(Total for Question 6 = 1 mark)

- 7 An electron has a momentum of $1.9 \times 10^{-24} \text{ kg m s}^{-1}$.
The kinetic energy of the electron is

- A $1.1 \times 10^{-21} \text{ J}$
 B $2.0 \times 10^{-18} \text{ J}$
 C $4.0 \times 10^{-18} \text{ J}$
 D $1.0 \times 10^6 \text{ J}$

(Total for Question 7 = 1 mark)



DO NOT WRITE IN THIS AREA

DO NOT WRITE IN THIS AREA

DO NOT WRITE IN THIS AREA

8 A particle of mass m and charge Q moves in a circle, perpendicular to a magnetic field of magnetic flux density B .

The graph shows the relationship between the radius of the orbit r and velocity v of the particle.

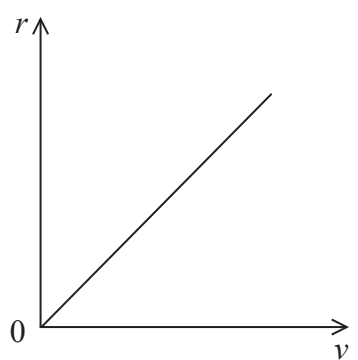

The gradient of the graph is given by

- A $\frac{m}{BQ}$
- B $\frac{BQ}{m}$
- C $\frac{1}{BQm}$
- D BQm

(Total for Question 8 = 1 mark)



Questions 9 and 10 refer to the diagram which shows tracks from a particle detector.

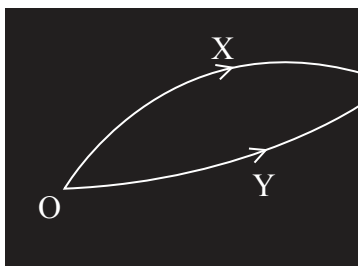

Two particles X and Y were created by the decay of a lambda particle at O.

The diagram shows the tracks of particles X and Y.

9 Which of the following is a valid conclusion from the information given?

- A X is a negatively charged particle.
- B Y is a positively charged particle.
- C The lambda particle is neutral.
- D The magnetic field is acting into the paper.

(Total for Question 9 = 1 mark)

10 Which of the following is a correct statement about momentum?

- A The momentum of X is equal to that of Y.
- B The total momentum of the system is zero.
- C The vector sum of the momenta of X and Y must equal that of the lambda particle.
- D The vector sum of the momenta of X and Y must equal zero.

(Total for Question 10 = 1 mark)

TOTAL FOR SECTION A = 10 MARKS

DO NOT WRITE IN THIS AREA

DO NOT WRITE IN THIS AREA

DO NOT WRITE IN THIS AREA



SECTION B

Answer ALL questions in the spaces provided.

11 Between 1909 and 1911 Rutherford's alpha particle scattering experiment provided evidence for the nuclear model of the atom. Alpha particles were fired at a thin gold foil and their paths observed.

(a) Describe the observations from the alpha particle scattering experiment.

(3)

.....

.....

.....

.....

.....

.....

.....

(b) An alpha particle approaches a gold nucleus. It reaches a distance of 4.5×10^{-14} m from the gold nucleus. Calculate the force between the alpha particle and the gold nucleus.

proton number for gold = 79

(3)

.....

.....

.....

.....

.....

.....

.....

Force =

(Total for Question 11 = 6 marks)

DO NOT WRITE IN THIS AREA



12 Regenerative braking is used in electric cars. When the driver applies the brakes the motor acts as an electric generator, making use of the rotation of the wheels as they slow down. This enables the battery to be charged whilst the car is braking.

The diagram shows a coil in a magnetic field which when rotating can be used as an electric generator.

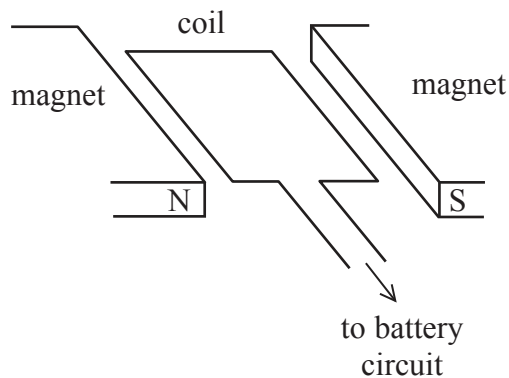

*(a) The coil rotates.

Explain how this produces a current in the coil.

(3)

.....

.....

.....

.....

.....

.....

.....

.....

.....

.....

(b) State why the current produced in the coil cannot be used directly to charge a battery.

(1)

.....

.....



(c) When regenerative braking is being used, explain how the magnitude of the generated e.m.f. changes as the driver brakes steadily.

(3)

.....

.....

.....

.....

.....

.....

.....

(Total for Question 12 = 7 marks)

DO NOT WRITE IN THIS AREA

DO NOT WRITE IN THIS AREA

DO NOT WRITE IN THIS AREA



13 Some lights are designed to dim gradually after being switched off. This can be done using a capacitor in a timer circuit.

The circuit diagram shows how a potential difference (p.d.) can be supplied across a resistor for a limited time.

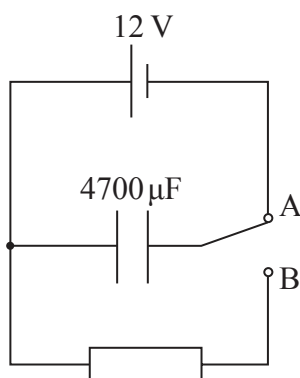

(a) When the switch is at position A, the capacitor charges.

(i) In terms of the movement of electrons, explain what happens to the capacitor as it becomes fully charged.

(2)

.....

.....

.....

.....

(ii) Calculate the energy stored in the charged capacitor.

(2)

.....

.....

.....

.....

Energy =



DO NOT WRITE IN THIS AREA

DO NOT WRITE IN THIS AREA

DO NOT WRITE IN THIS AREA

(b) The switch is moved to position B and the capacitor discharges through the resistor.

(i) Describe what happens to the current through the resistor.

(2)

.....

.....

.....

(ii) For the circuit shown, the p.d. across the capacitor falls to 10% of the supply p.d. after 25 s.

Calculate the resistance of the resistor in the circuit.

(3)

.....

.....

.....

.....

.....

Resistance =

(Total for Question 13 = 9 marks)



14 A mass spectrometer is a device used to identify atoms by measuring the mass-charge ratio $\frac{m}{Q}$ of their ions.

Ionised atoms in a vacuum are accelerated from rest through a potential difference V and then enter an evacuated tube.

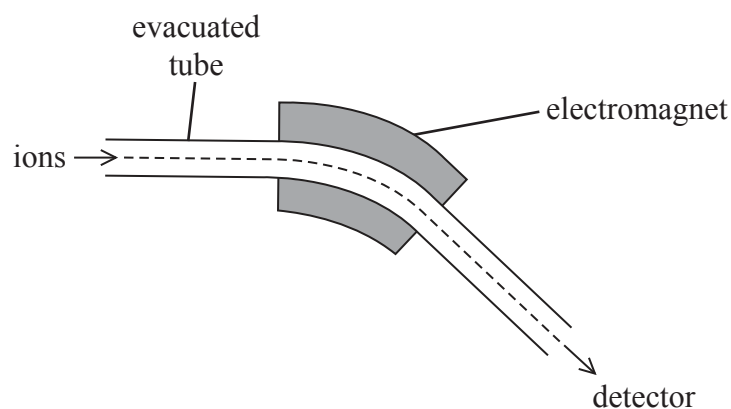

- (a) An ion of mass m is accelerated to a velocity v .
Show that the mass-charge ratio of the ion is given by

$$\frac{m}{Q} = \frac{2V}{v^2}$$

(2)

.....

.....

.....

.....



DO NOT WRITE IN THIS AREA

DO NOT WRITE IN THIS AREA

DO NOT WRITE IN THIS AREA

BLANK PAGE



DO NOT WRITE IN THIS AREA

DO NOT WRITE IN THIS AREA

DO NOT WRITE IN THIS AREA

15 In a bowling game, a player rolls a small ball along the ground. The diagram shows the action of the player as he starts to swing his arm forward at A, to the point when the ball is rolling along the ground at C.

The player exerts a forward force on the ball between A and B.

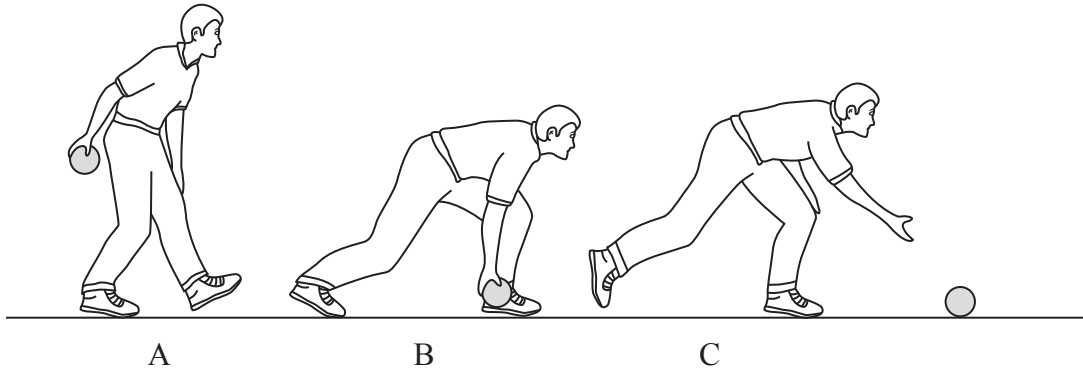

(a) (i) State how the motion of the ball at C differs from that at B. (2)

.....

.....

.....

.....

(ii) The player applies a forward force for 0.20s and the ball leaves the player's hand at a speed of 3.0 m s^{-1} .

Calculate the average forward force that the player applies to the ball.

mass of ball, $m_1 = 1.5 \text{ kg}$ (2)

.....

.....

.....

Average forward force =



- (b) The ball rolls along the ground until it collides with a stationary ball of mass 1.2 kg. After the collision both balls roll off at an angle to the original direction of the moving ball as shown in the diagrams.

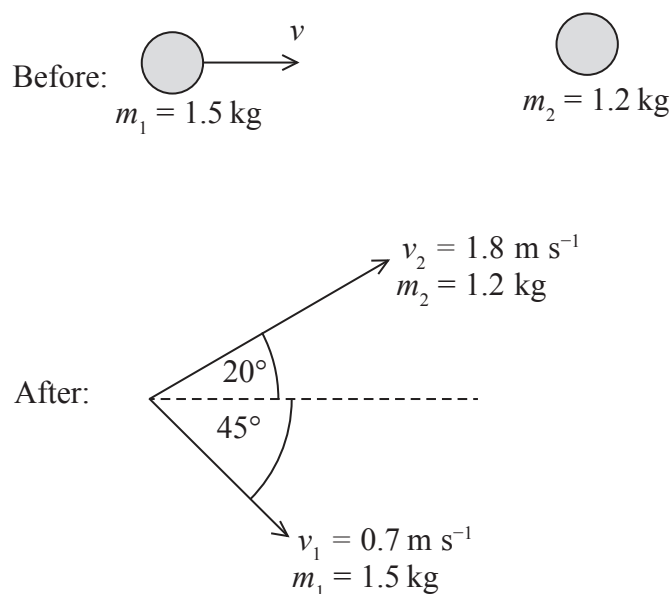

After the collision:

- the 1.5 kg ball travels at 0.7 m s^{-1} at an angle of 45° to its original direction
 - the 1.2 kg ball travels at 1.8 m s^{-1} at an angle of 20° to the original direction of the moving ball.
- (i) Show that the velocity v of the first ball as it collides with the second ball is about 2 m s^{-1} .

(3)



(ii) By means of a suitable calculation, show that the collision is inelastic.

(2)

.....

.....

.....

.....

(Total for Question 15 = 9 marks)

DO NOT WRITE IN THIS AREA

DO NOT WRITE IN THIS AREA

DO NOT WRITE IN THIS AREA



16 The International Space Station (ISS) is in orbit at a height of 400 km above the Earth's surface. The ISS completes 15.5 orbits in 24 hours.

(a) Calculate the angular velocity of the ISS in radians per second.

(2)

.....
.....
.....
.....

Angular velocity = rad s⁻¹

*(b) A student suggests:

“The ISS is travelling at a constant speed, so, according to Newton’s laws, there will be no resultant force acting on it.”

Criticise this suggestion.

(3)

.....
.....
.....
.....
.....
.....

(c) Calculate the magnitude of the centripetal force acting on the ISS.

mass of ISS = 4.19×10^5 kg

radius of Earth = 6400 km

(2)

.....
.....
.....
.....

Force =

(Total for Question 16 = 7 marks)



DO NOT WRITE IN THIS AREA

DO NOT WRITE IN THIS AREA

DO NOT WRITE IN THIS AREA

17 A student set up an experiment to determine the magnetic flux density between two magnadur magnets. A magnadur magnet has its north and south poles on opposite large rectangular faces. The two magnets were attached to a yoke, with opposite poles facing, as shown in the diagram.

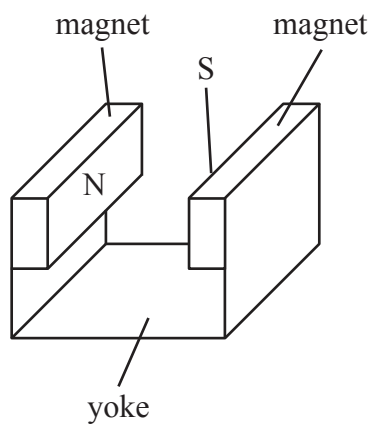

The student zeroed the balance and then placed the magnets and yoke on it. The reading increased to 136.38 g.

A conducting rod connected to a d.c. power supply was held stationary between the magnets as shown. An ammeter was used to measure the current through the conducting rod.



The circuit diagram shows the arrangement when viewed from above.

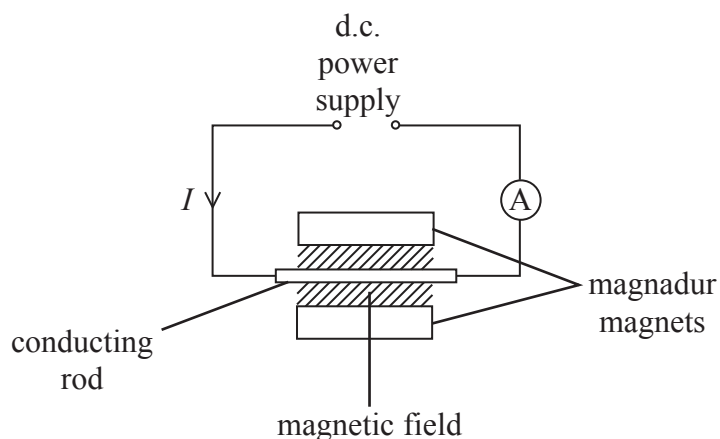

The power supply was switched on. The student increased the current through the conducting rod and the corresponding reading on the balance was recorded.

The following results were obtained.

Current / A	Reading on balance / g
0	136.38
0.5	136.52
1.0	136.66
1.5	136.79
2.0	136.93
2.5	137.06

- (a) Add an arrow to the circuit diagram to indicate the direction of the magnetic field between the magnets. Justify your answer.

(4)

.....

.....

.....

.....

.....

.....



(b) Describe how the results can be used to determine the magnetic flux density by a graphical method. You are not expected to do the calculations.

(6)

DO NOT WRITE IN THIS AREA

DO NOT WRITE IN THIS AREA

DO NOT WRITE IN THIS AREA

(Total for Question 17 = 10 marks)



18 The equation for β^+ decay is

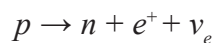

(a) Using information in the table, describe how a proton changes into a neutron.

Type of quark	Charge / e
u	+2/3
d	-1/3

(2)

.....

.....

.....

.....

(b) With reference to the charges of the particles, show that this decay is possible.

(2)

.....

.....

.....

.....

DO NOT WRITE IN THIS AREA

DO NOT WRITE IN THIS AREA

DO NOT WRITE IN THIS AREA



- (c) The kinetic energy of the positron is 1.58 MeV. It annihilates with a stationary electron and two photons of equal energy are emitted.

Calculate the wavelength of the emitted photons.

$$\text{mass of stationary electron} = 0.511 \text{ MeV}/c^2$$

$$\text{mass of stationary positron} = 0.511 \text{ MeV}/c^2$$

(4)

Wavelength =

- (d) Linear accelerators (linacs) can produce electrons with energies up to 20 GeV.

- (i) Calculate the de Broglie wavelength associated with 20 GeV electrons.
At these energies, the energy and momentum of a particle are connected by the relativistic equation $E = pc$.

(3)

Wavelength =



(ii) Experiments have been carried out where these 20 GeV electrons are aimed at a hydrogen target which consists of protons. Suggest, with reasons, what happens to the path of the electrons.

(2)

.....

.....

.....

.....

(Total for Question 18 = 13 marks)

TOTAL FOR SECTION B = 70 MARKS

TOTAL FOR PAPER = 80 MARKS

DO NOT WRITE IN THIS AREA

DO NOT WRITE IN THIS AREA

DO NOT WRITE IN THIS AREA



List of data, formulae and relationships

Acceleration of free fall	$g = 9.81 \text{ m s}^{-2}$	(close to Earth's surface)
Boltzmann constant	$k = 1.38 \times 10^{-23} \text{ J K}^{-1}$	
Coulomb's law constant	$k = 1/4\pi\epsilon_0$ $= 8.99 \times 10^9 \text{ N m}^2 \text{ C}^{-2}$	
Electron charge	$e = -1.60 \times 10^{-19} \text{ C}$	
Electron mass	$m_e = 9.11 \times 10^{-31} \text{ kg}$	
Electronvolt	$1 \text{ eV} = 1.60 \times 10^{-19} \text{ J}$	
Gravitational constant	$G = 6.67 \times 10^{-11} \text{ N m}^2 \text{ kg}^{-2}$	
Gravitational field strength	$g = 9.81 \text{ N kg}^{-1}$	(close to Earth's surface)
Permittivity of free space	$\epsilon_0 = 8.85 \times 10^{-12} \text{ F m}^{-1}$	
Planck constant	$h = 6.63 \times 10^{-34} \text{ J s}$	
Proton mass	$m_p = 1.67 \times 10^{-27} \text{ kg}$	
Speed of light in a vacuum	$c = 3.00 \times 10^8 \text{ m s}^{-1}$	
Stefan-Boltzmann constant	$\sigma = 5.67 \times 10^{-8} \text{ W m}^{-2} \text{ K}^{-4}$	
Unified atomic mass unit	$u = 1.66 \times 10^{-27} \text{ kg}$	

Unit 1

Mechanics

Kinematic equations of motion

$$v = u + at$$

$$s = ut + \frac{1}{2}at^2$$

$$v^2 = u^2 + 2as$$

Forces

$$\Sigma F = ma$$

$$g = F/m$$

$$W = mg$$

Work and energy

$$\Delta W = F\Delta s$$

$$E_k = \frac{1}{2}mv^2$$

$$\Delta E_{\text{grav}} = mg\Delta h$$

Materials

Stokes' law

$$F = 6\pi\eta rv$$

Hooke's law

$$F = k\Delta x$$

Density

$$\rho = m/V$$

Pressure

$$p = F/A$$

Young modulus

$$E = \sigma/\epsilon \text{ where}$$

Stress $\sigma = F/A$

Strain $\epsilon = \Delta x/x$

Elastic strain energy

$$E_{\text{el}} = \frac{1}{2}F\Delta x$$

DO NOT WRITE IN THIS AREA

DO NOT WRITE IN THIS AREA

DO NOT WRITE IN THIS AREA



Unit 2

Waves

Wave speed $v = f\lambda$

Refractive index ${}_1\mu_2 = \sin i / \sin r = v_1 / v_2$

Electricity

Potential difference $V = W/Q$

Resistance $R = V/I$

Electrical power, energy and efficiency
 $P = VI$
 $P = I^2R$
 $P = V^2/R$
 $W = VI t$

$$\% \text{ efficiency} = \frac{\text{useful energy output}}{\text{total energy input}} \times 100$$

$$\% \text{ efficiency} = \frac{\text{useful power output}}{\text{total power input}} \times 100$$

Resistivity $R = \rho l/A$

Current $I = \Delta Q / \Delta t$
 $I = nqvA$

Resistors in series $R = R_1 + R_2 + R_3$

Resistors in parallel $\frac{1}{R} = \frac{1}{R_1} + \frac{1}{R_2} + \frac{1}{R_3}$

Quantum physics

Photon model $E = hf$

Einstein's photoelectric equation $hf = \phi + \frac{1}{2}mv_{\text{max}}^2$

DO NOT WRITE IN THIS AREA

DO NOT WRITE IN THIS AREA

DO NOT WRITE IN THIS AREA



Unit 4

Mechanics

Momentum	$p = mv$
Kinetic energy of a non-relativistic particle	$E_k = p^2/2m$
Motion in a circle	$v = \omega r$ $T = 2\pi/\omega$ $F = ma = mv^2/r$ $a = v^2/r$ $a = r\omega^2$

Fields

Coulomb's law	$F = kQ_1Q_2/r^2$ where $k = 1/4\pi\epsilon_0$
Electric field	$E = F/Q$ $E = kQ/r^2$ $E = V/d$
Capacitance	$C = Q/V$
Energy stored in capacitor	$W = \frac{1}{2}QV$
Capacitor discharge	$Q = Q_0 e^{-t/RC}$
In a magnetic field	$F = BIl \sin \theta$ $F = Bqv \sin \theta$ $r = p/BQ$
Faraday's and Lenz's Laws	$\epsilon = -d(N\phi)/dt$

Particle physics

Mass-energy	$\Delta E = c^2 \Delta m$
de Broglie wavelength	$\lambda = h/p$

DO NOT WRITE IN THIS AREA

DO NOT WRITE IN THIS AREA

DO NOT WRITE IN THIS AREA



DO NOT WRITE IN THIS AREA

DO NOT WRITE IN THIS AREA

DO NOT WRITE IN THIS AREA

BLANK PAGE

